

DW_SE5/2003

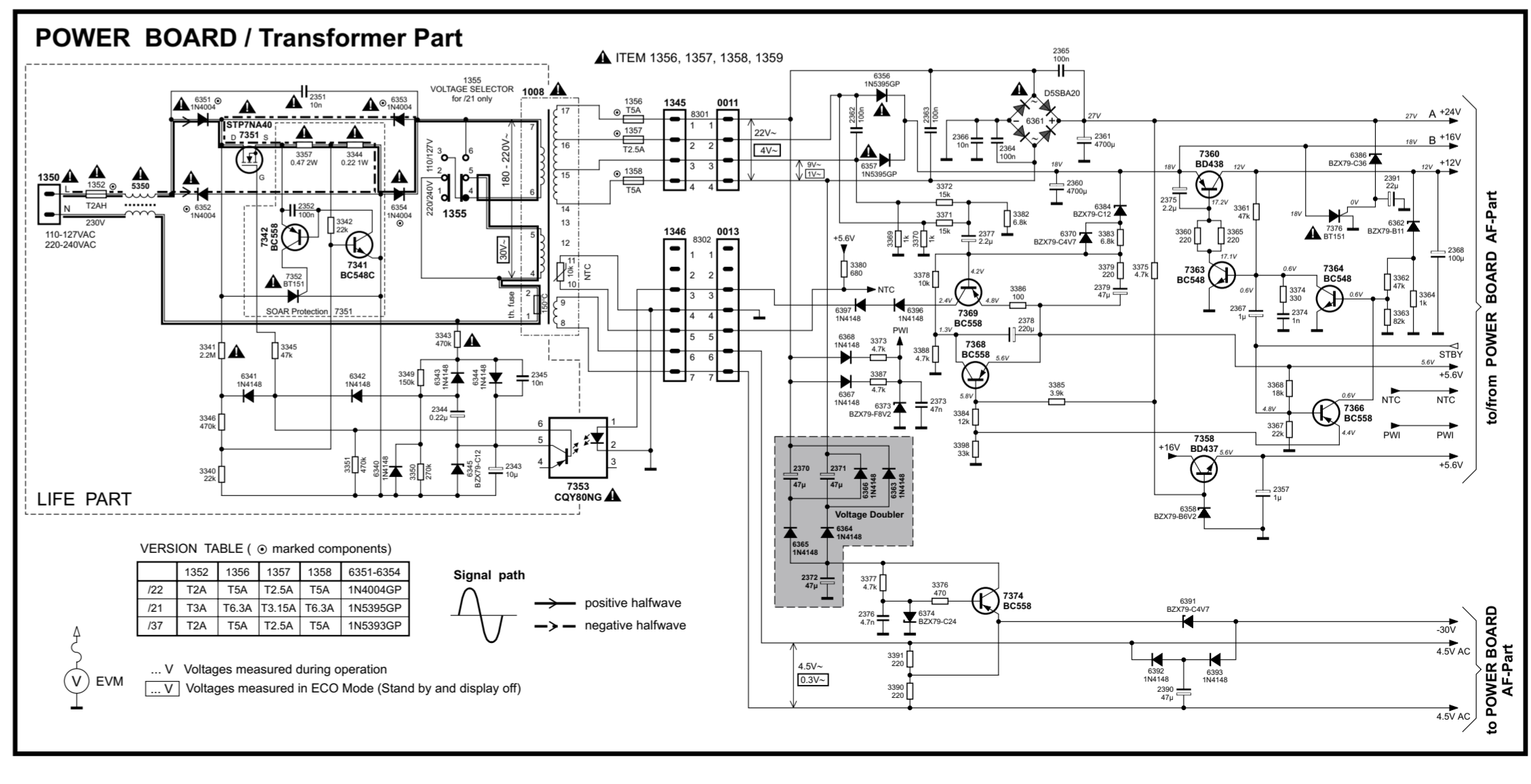

FUNCTIONAL DIAGRAM TAPE PART

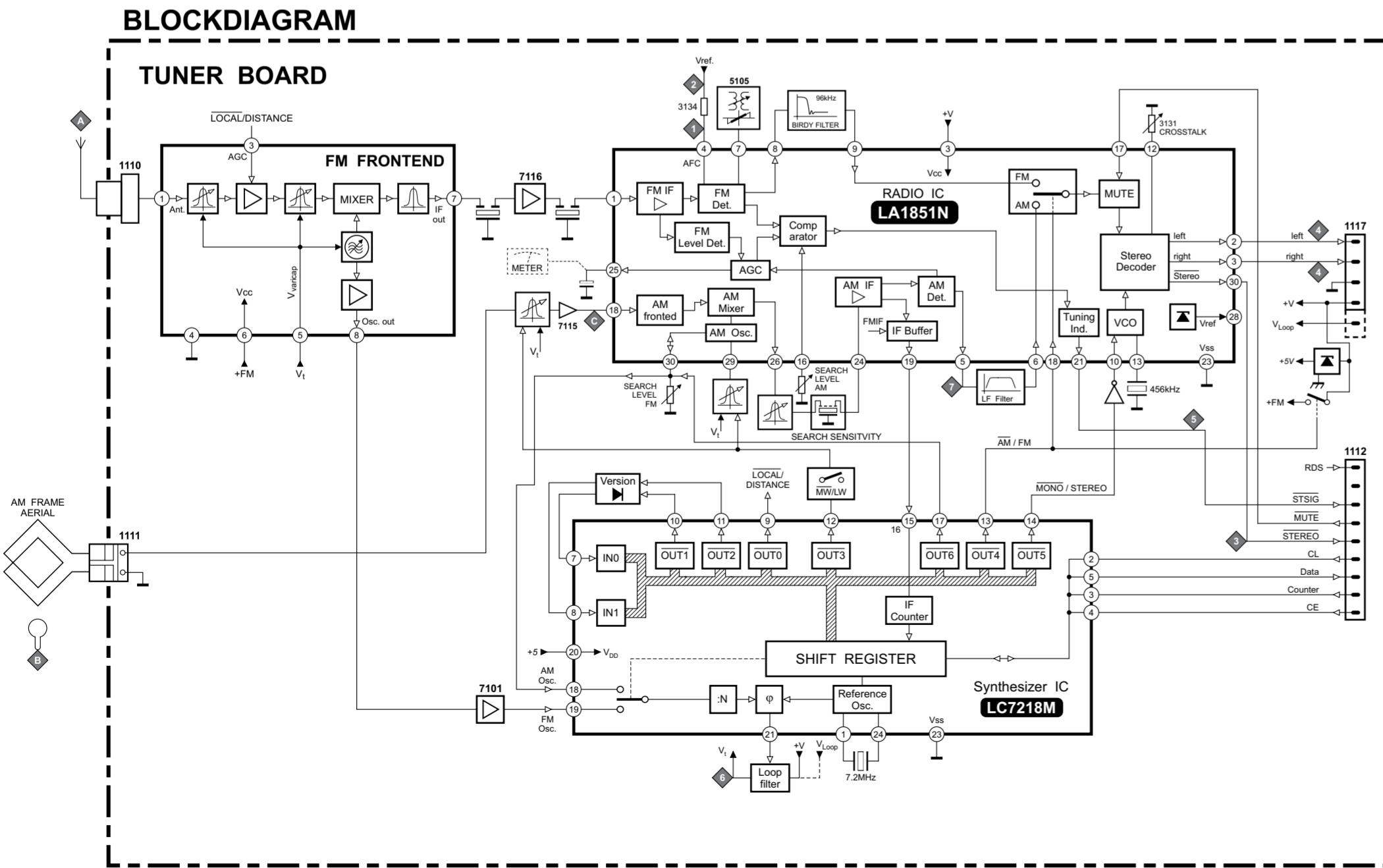
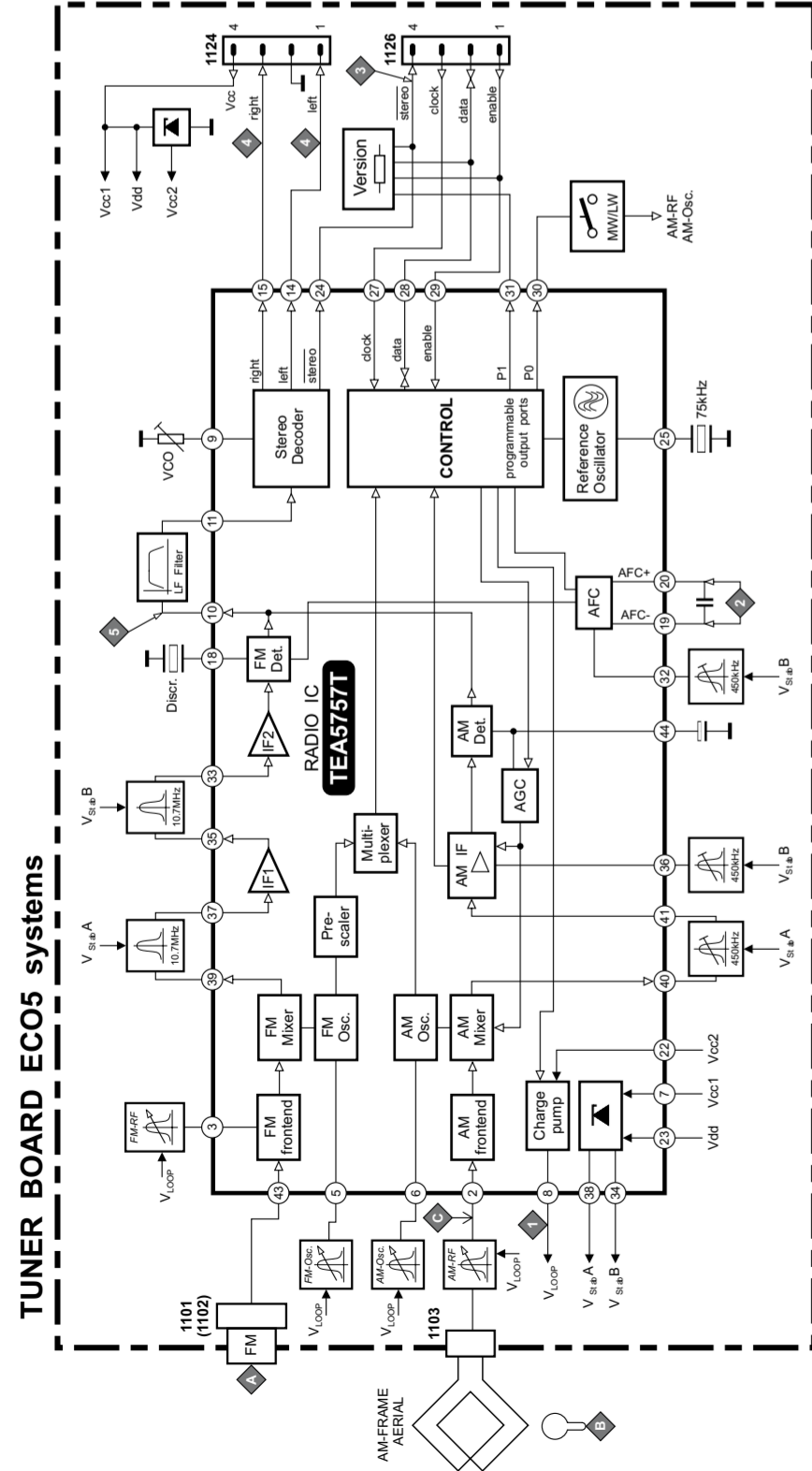
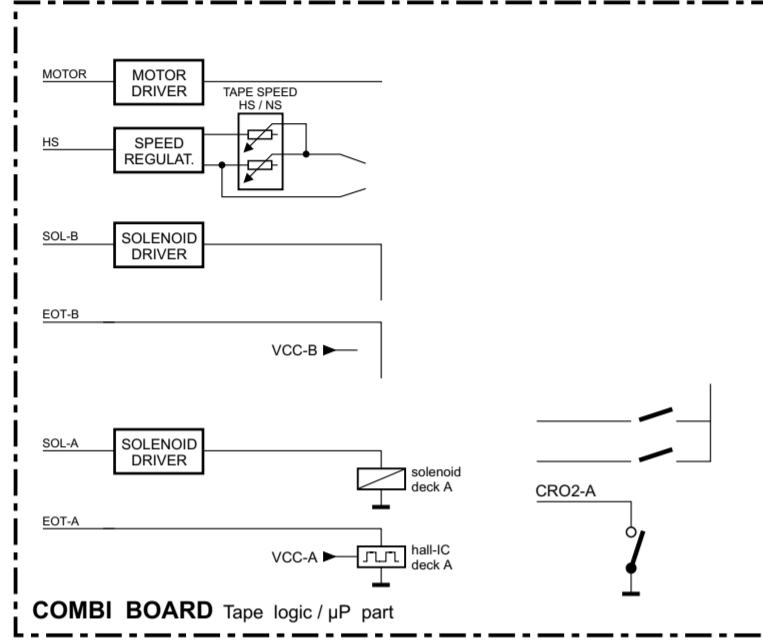
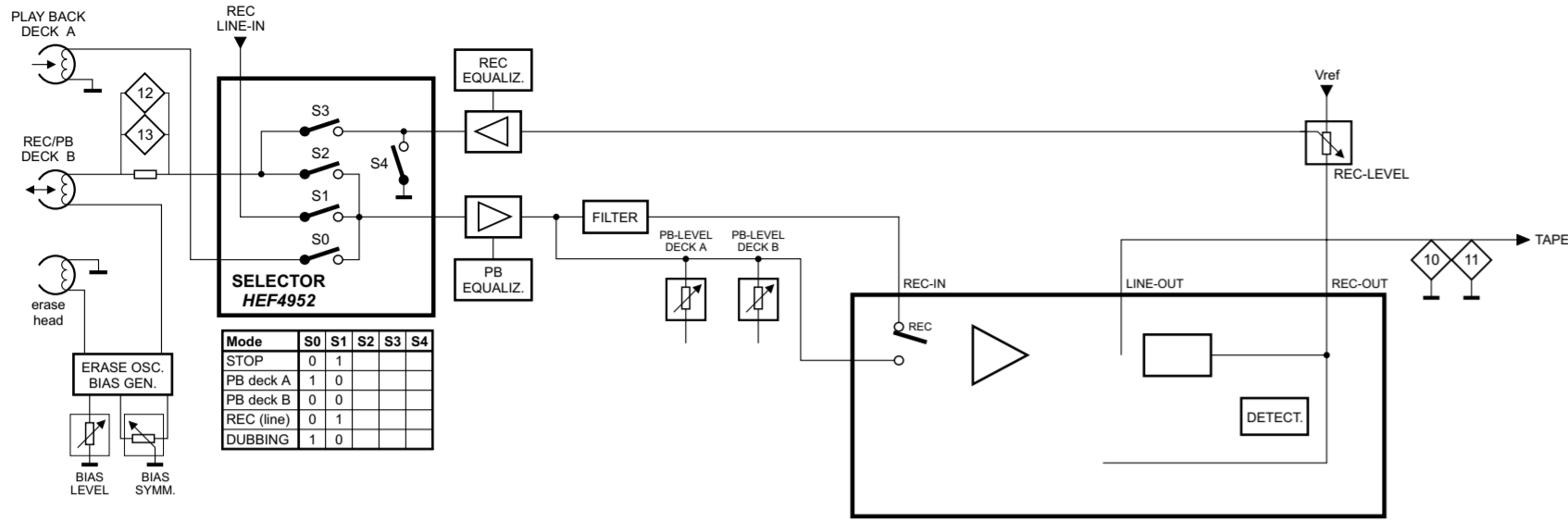

BLOCKDIAGRAM

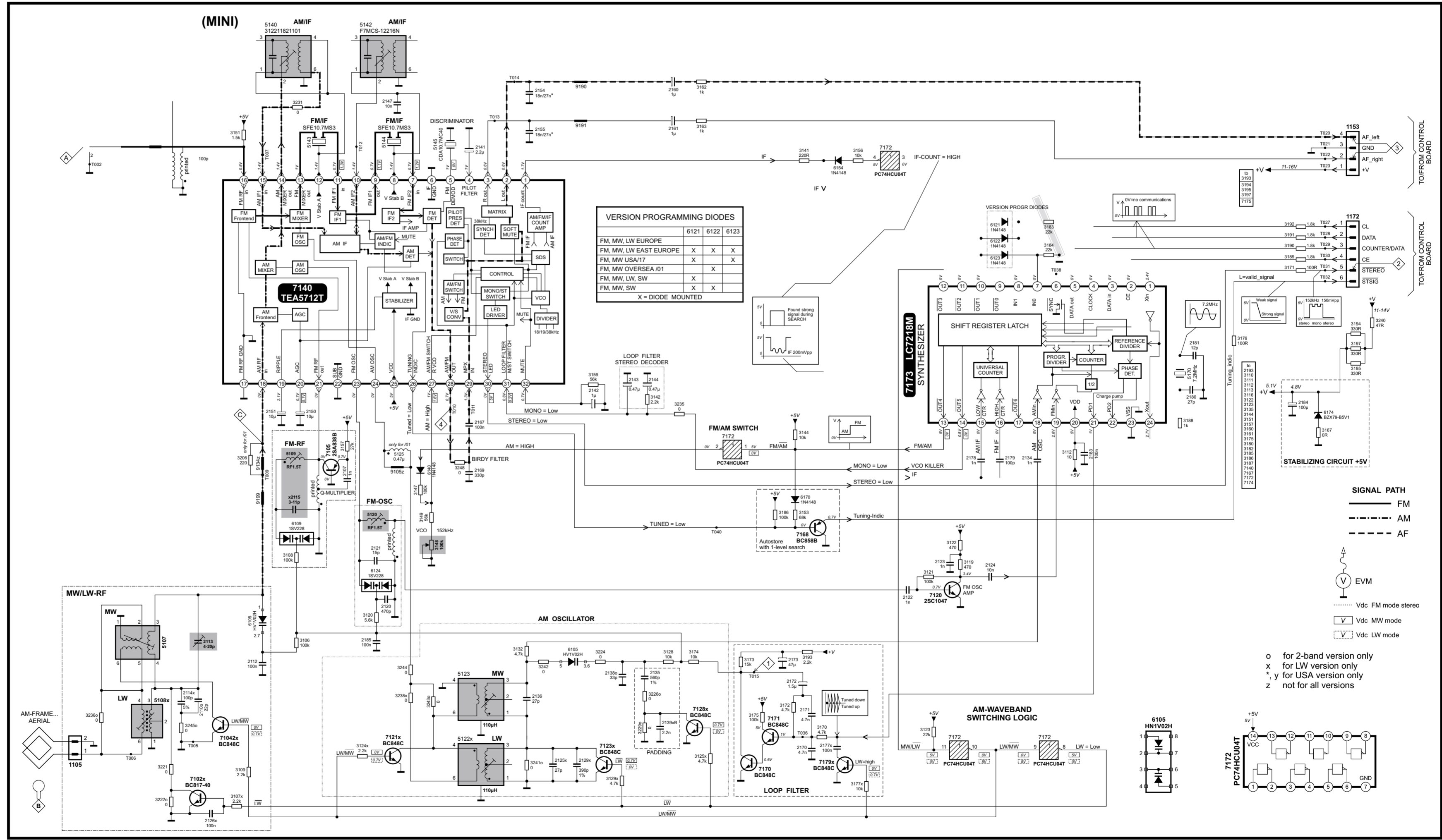
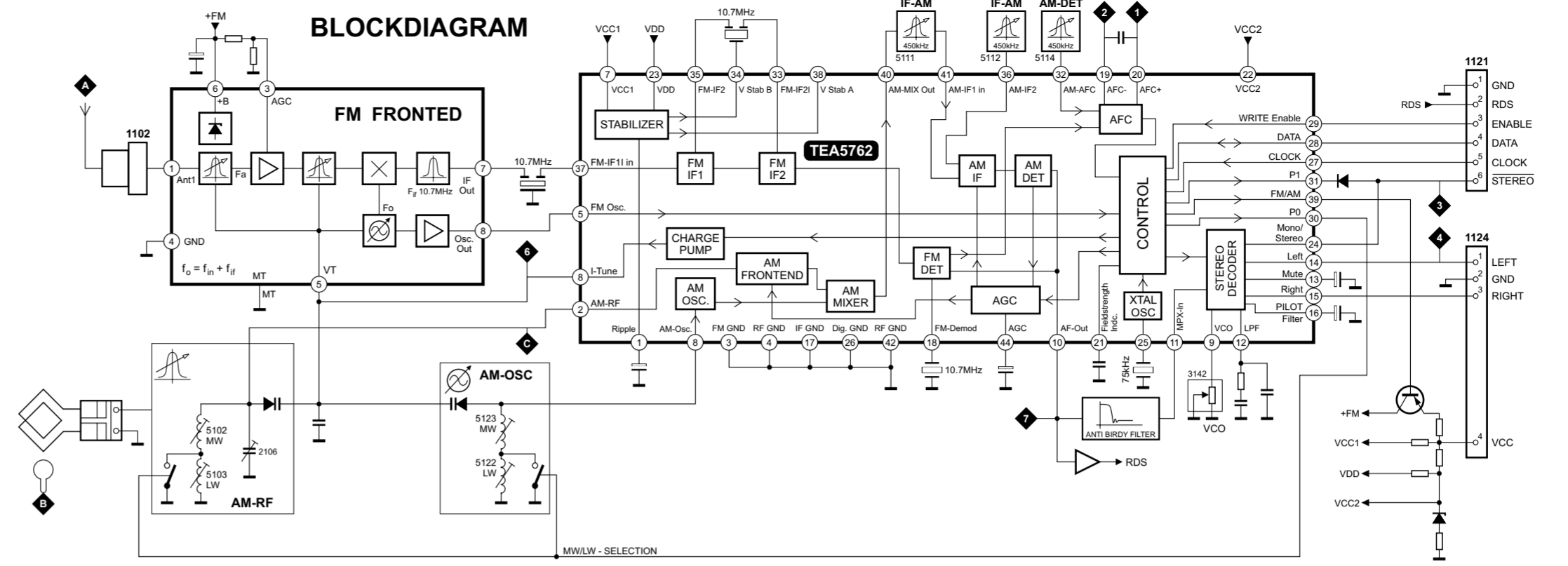

COMBI AF-PART

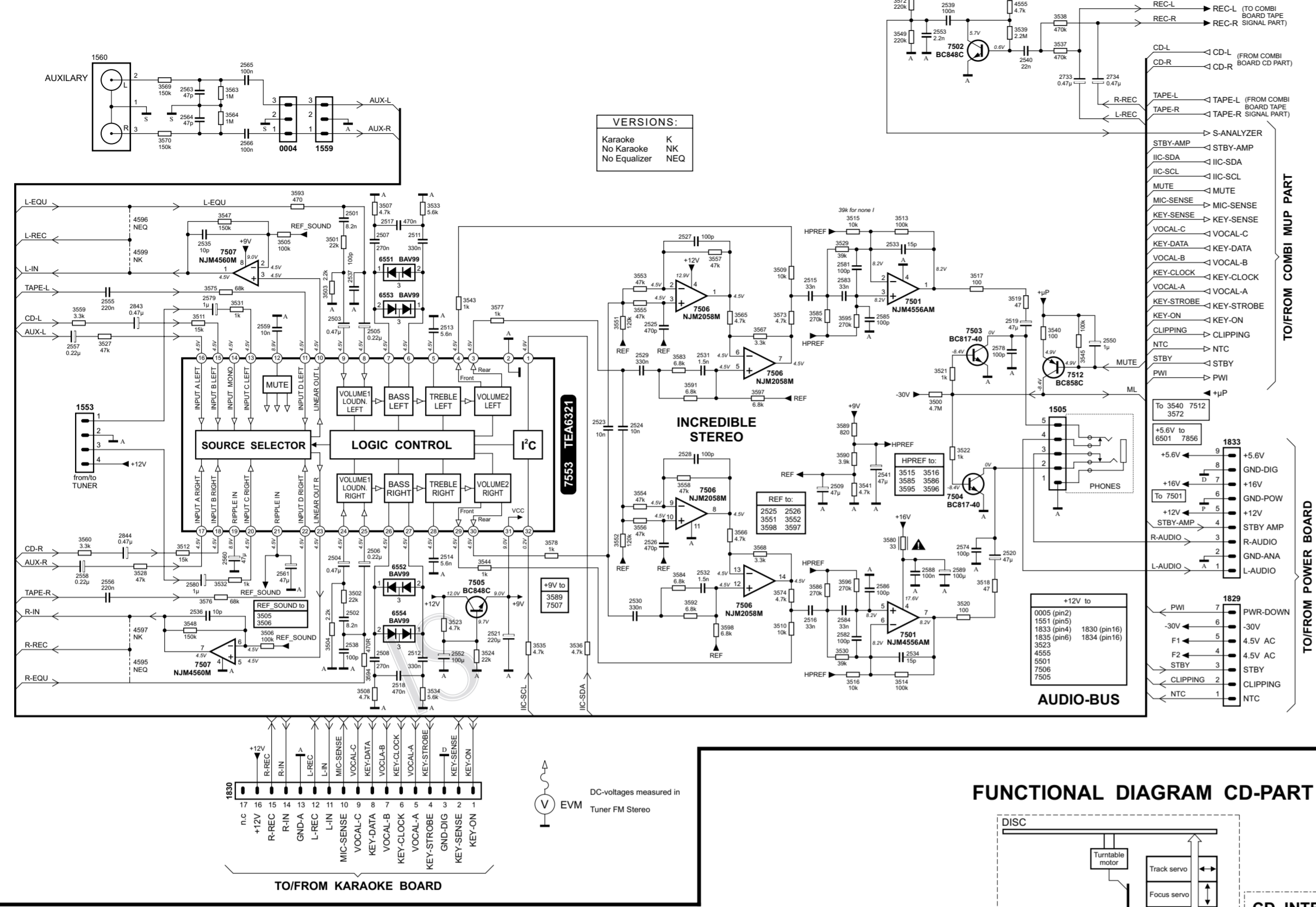

DW_SE5/2003

FUNCTIONAL DIAGRAM AF-PART

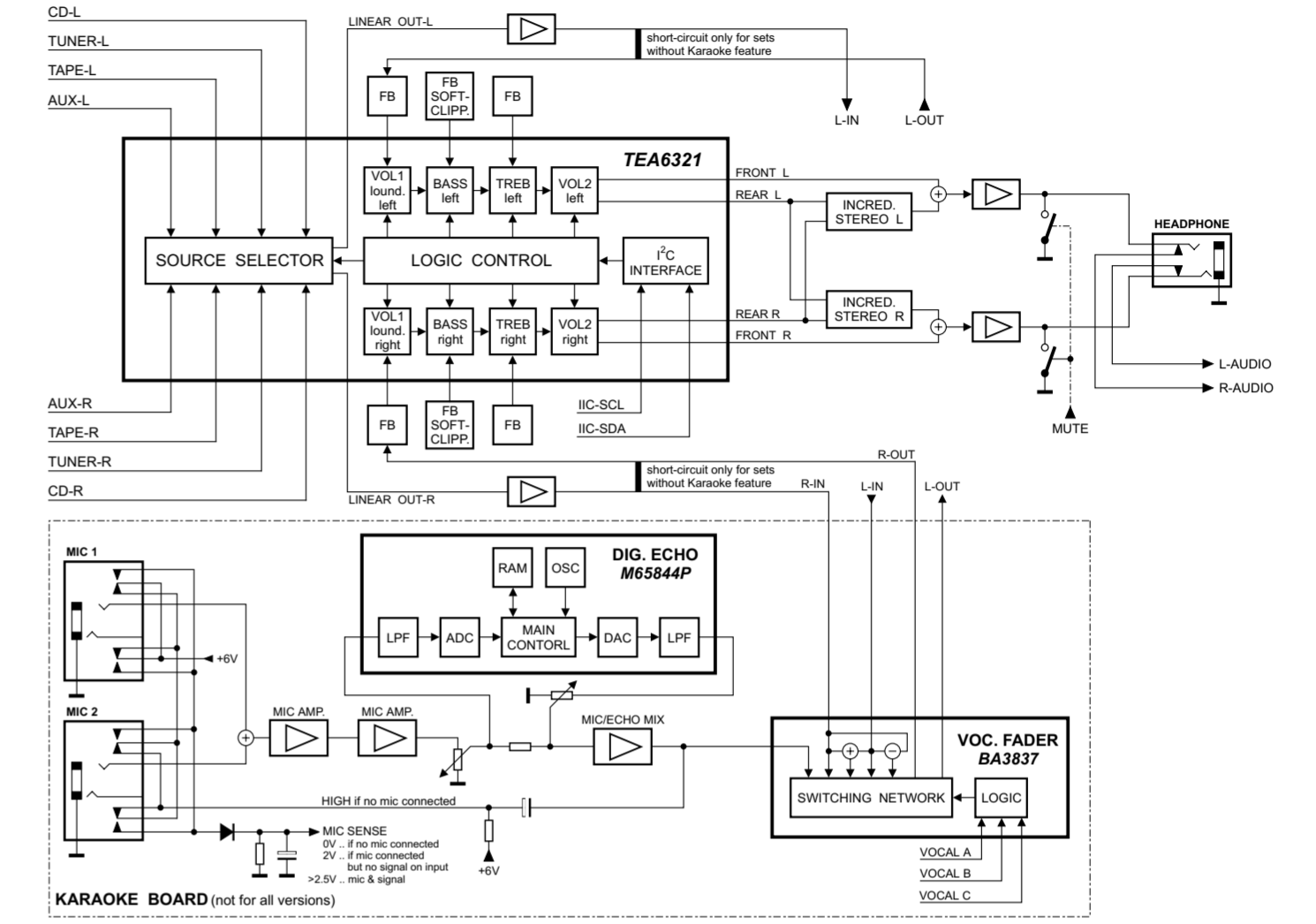

FUNCTIONAL DIAGRAM CD-PART

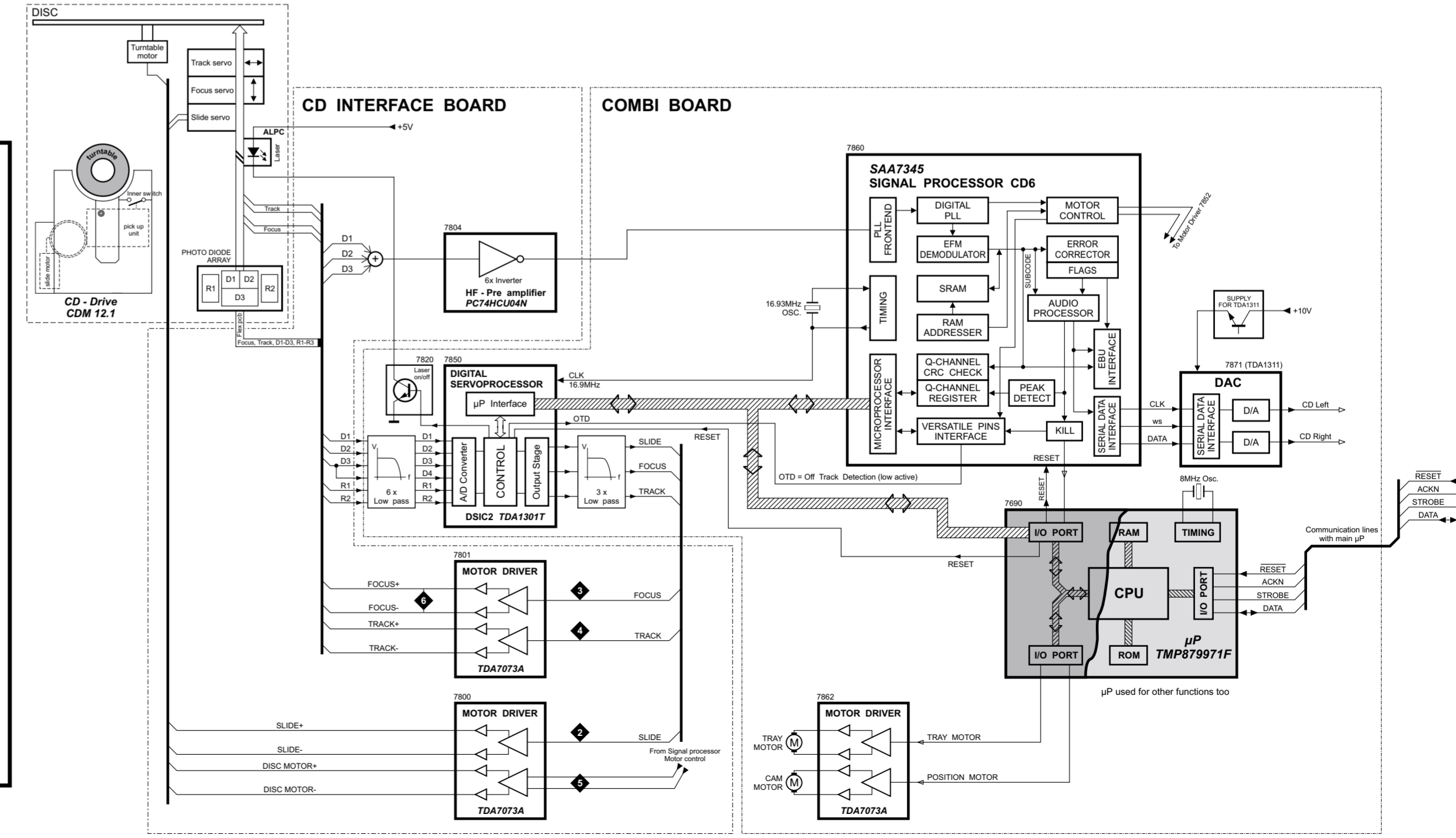

POWER BOARD / AF-Part

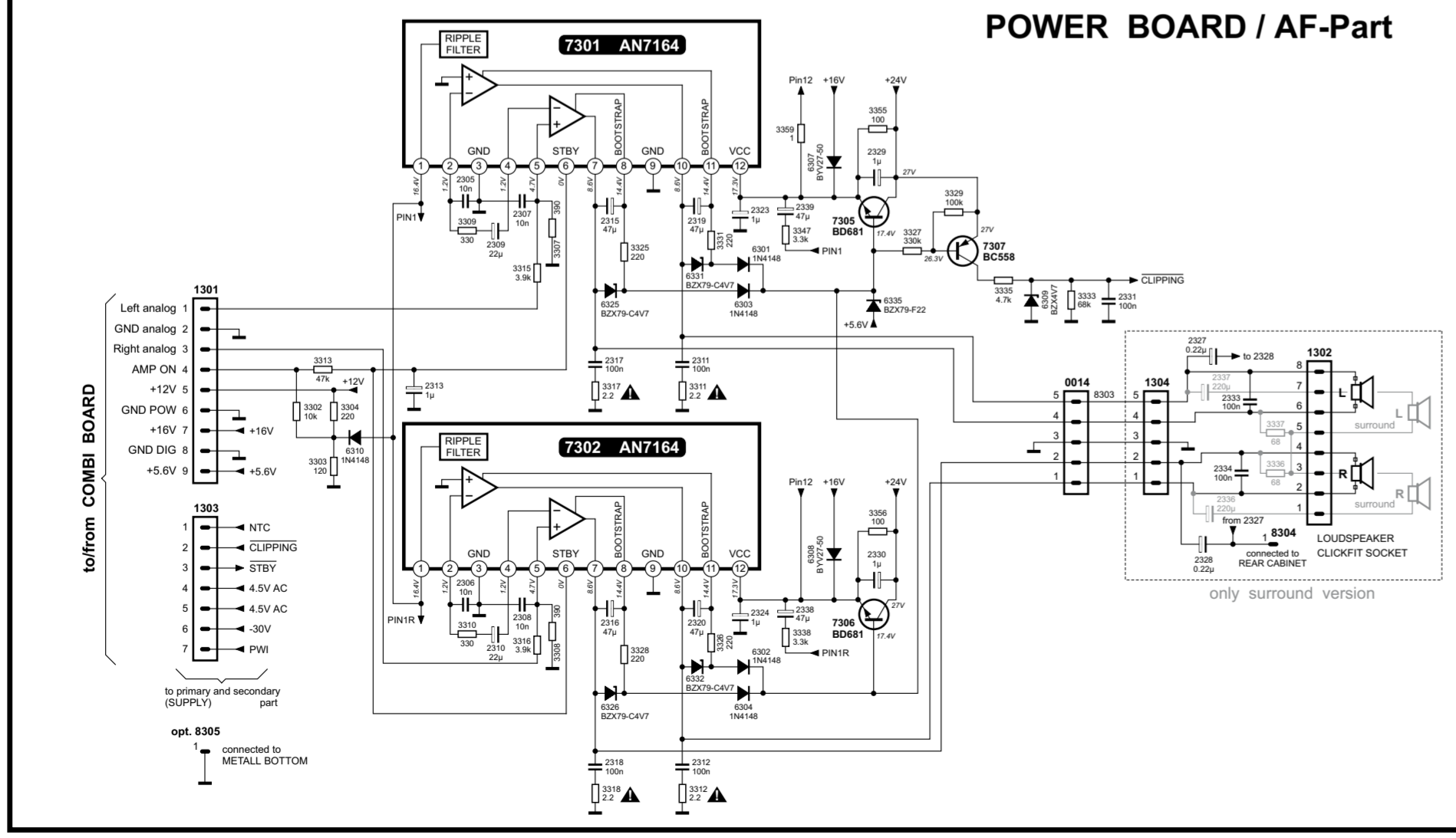

CONTROL BOARD

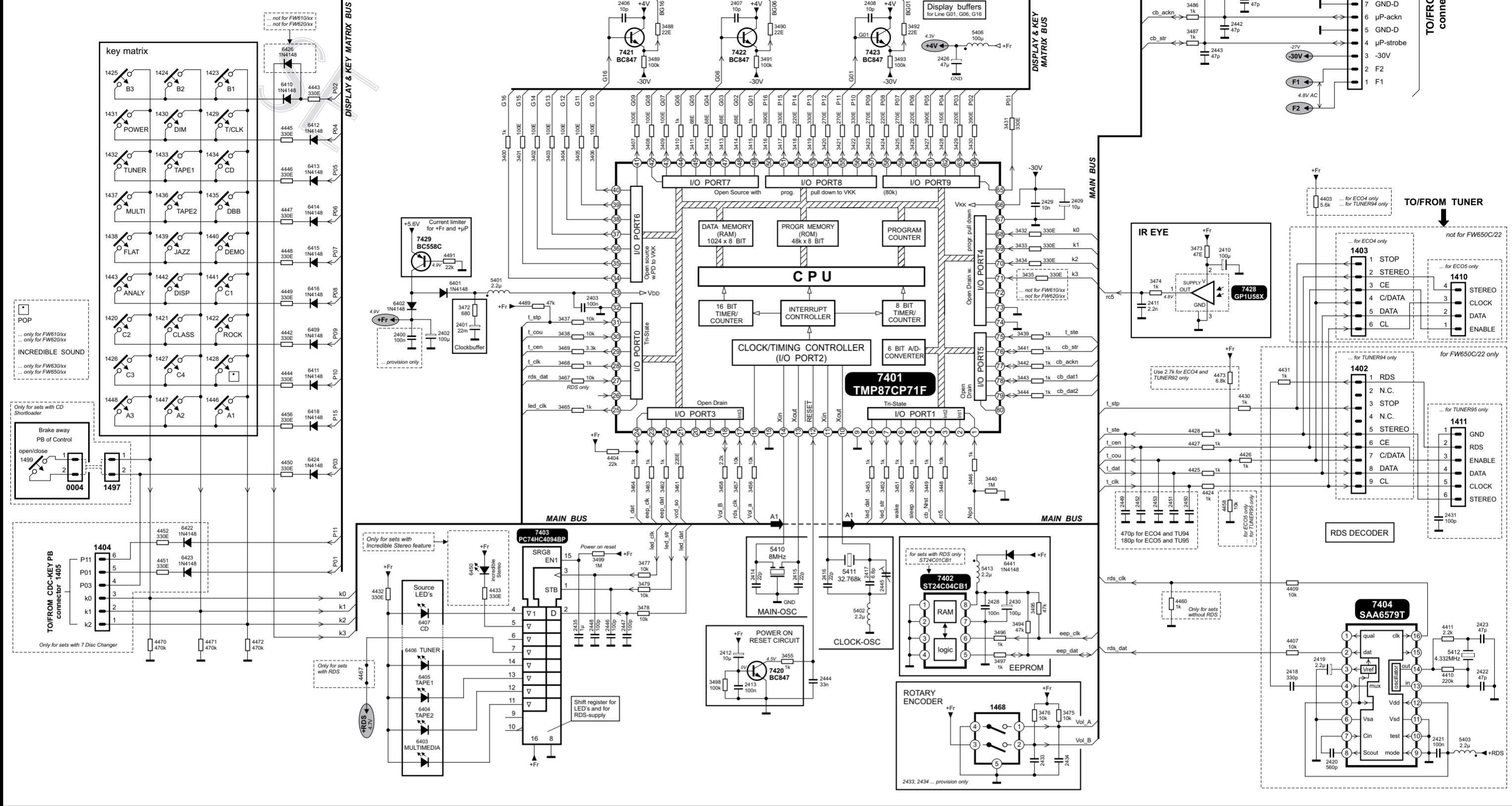
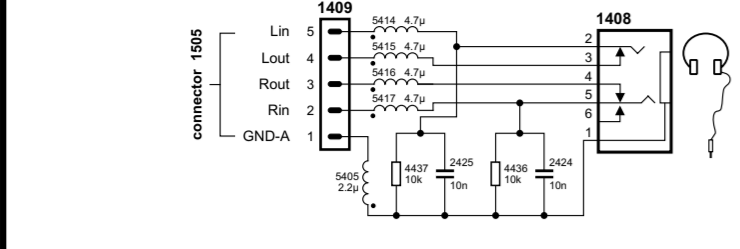
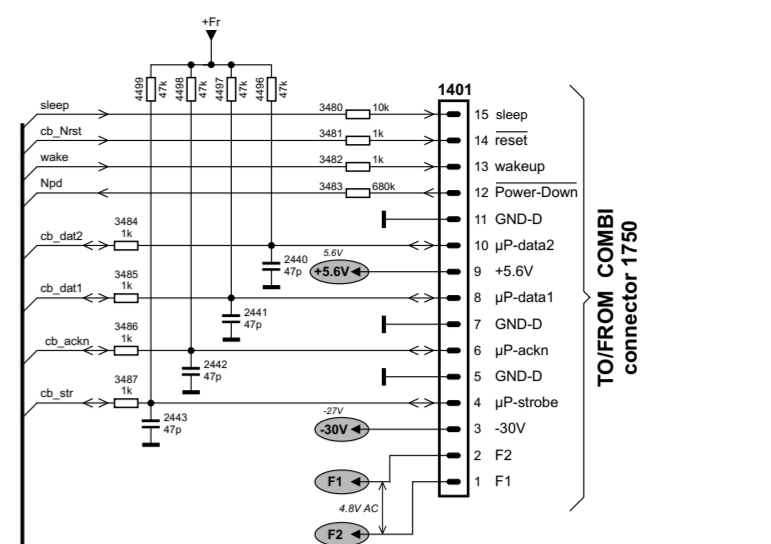
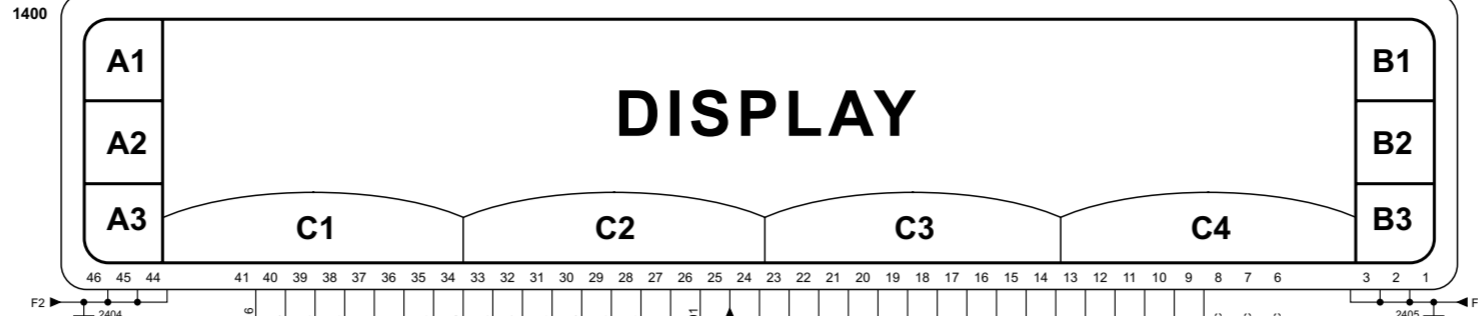

CONTROL BOARD

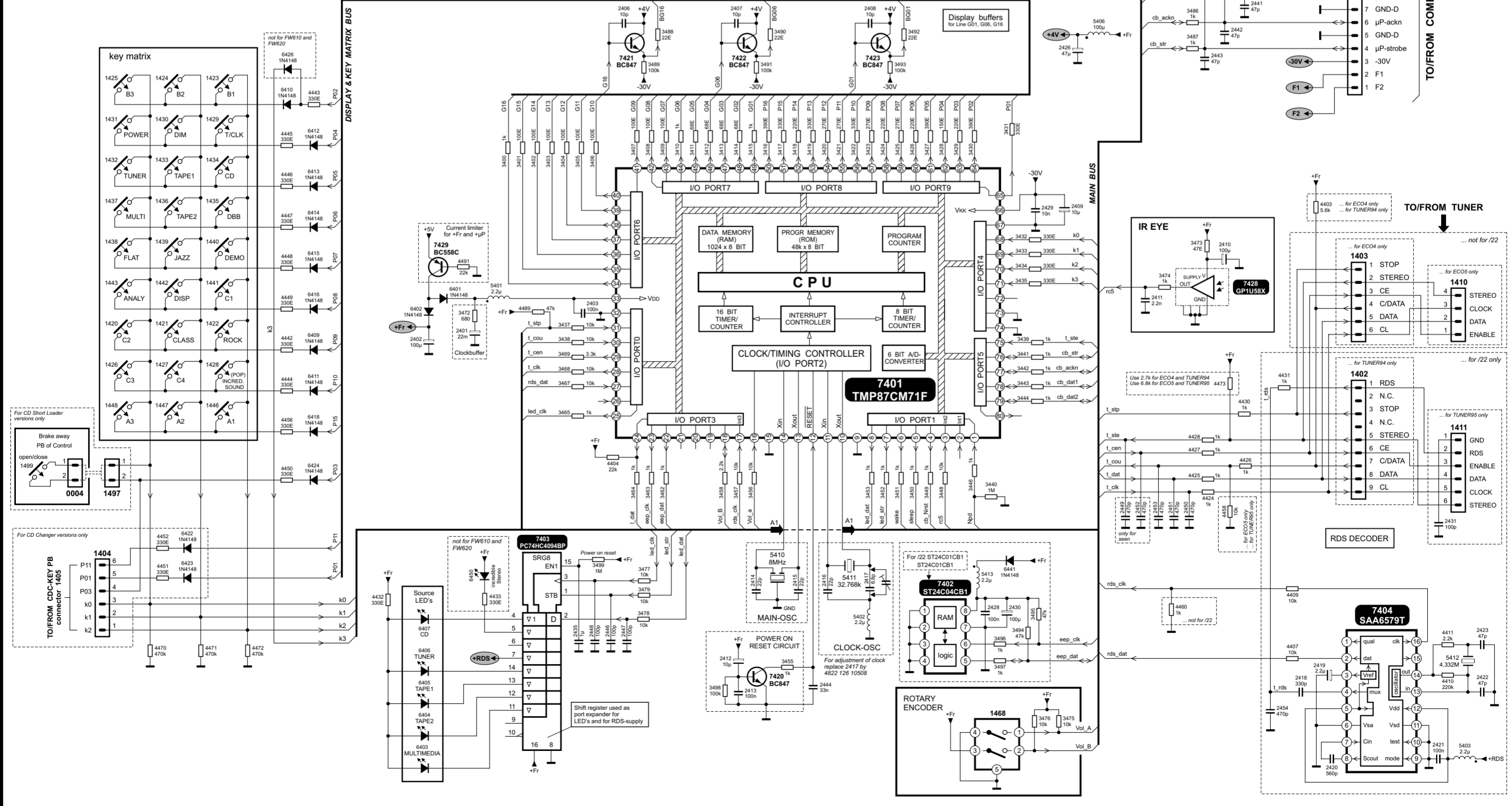
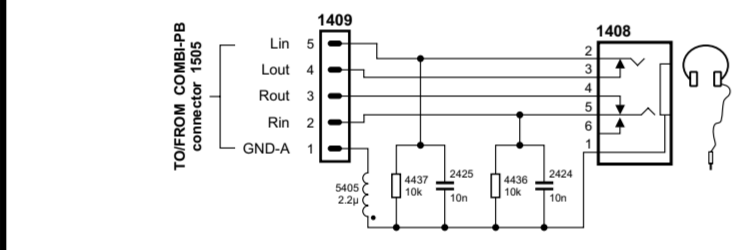
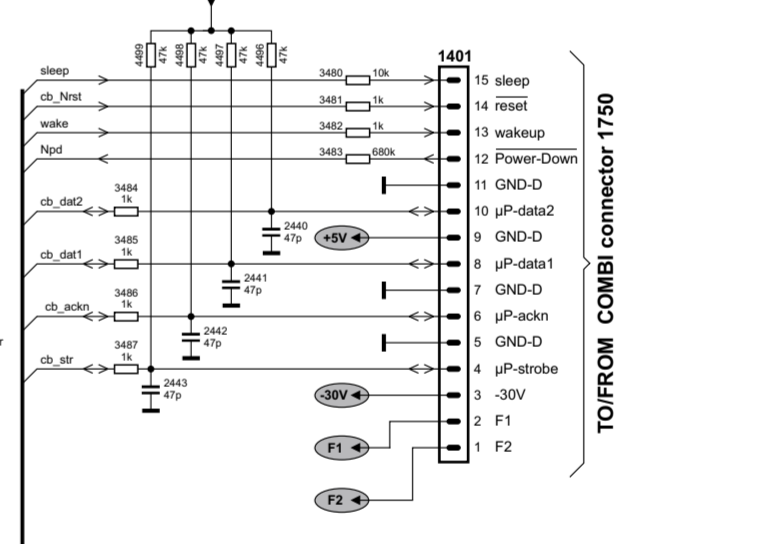
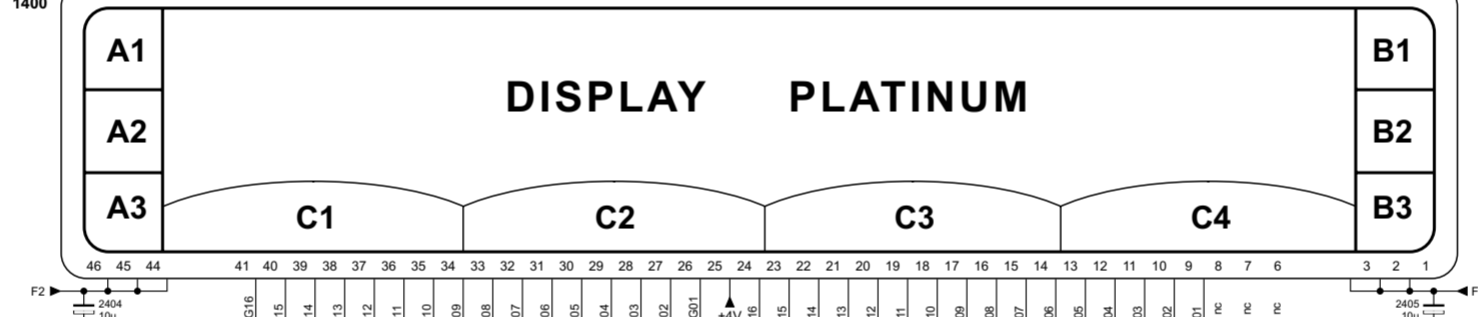

FUNCTIONAL DIAGRAM CDC7 Module

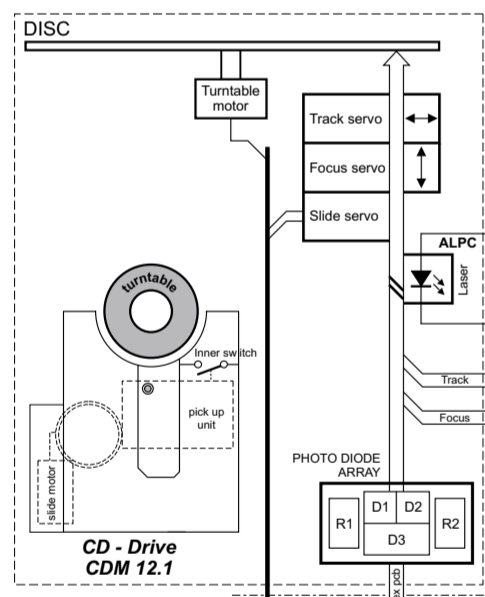

CD-INTERFACE BOARD

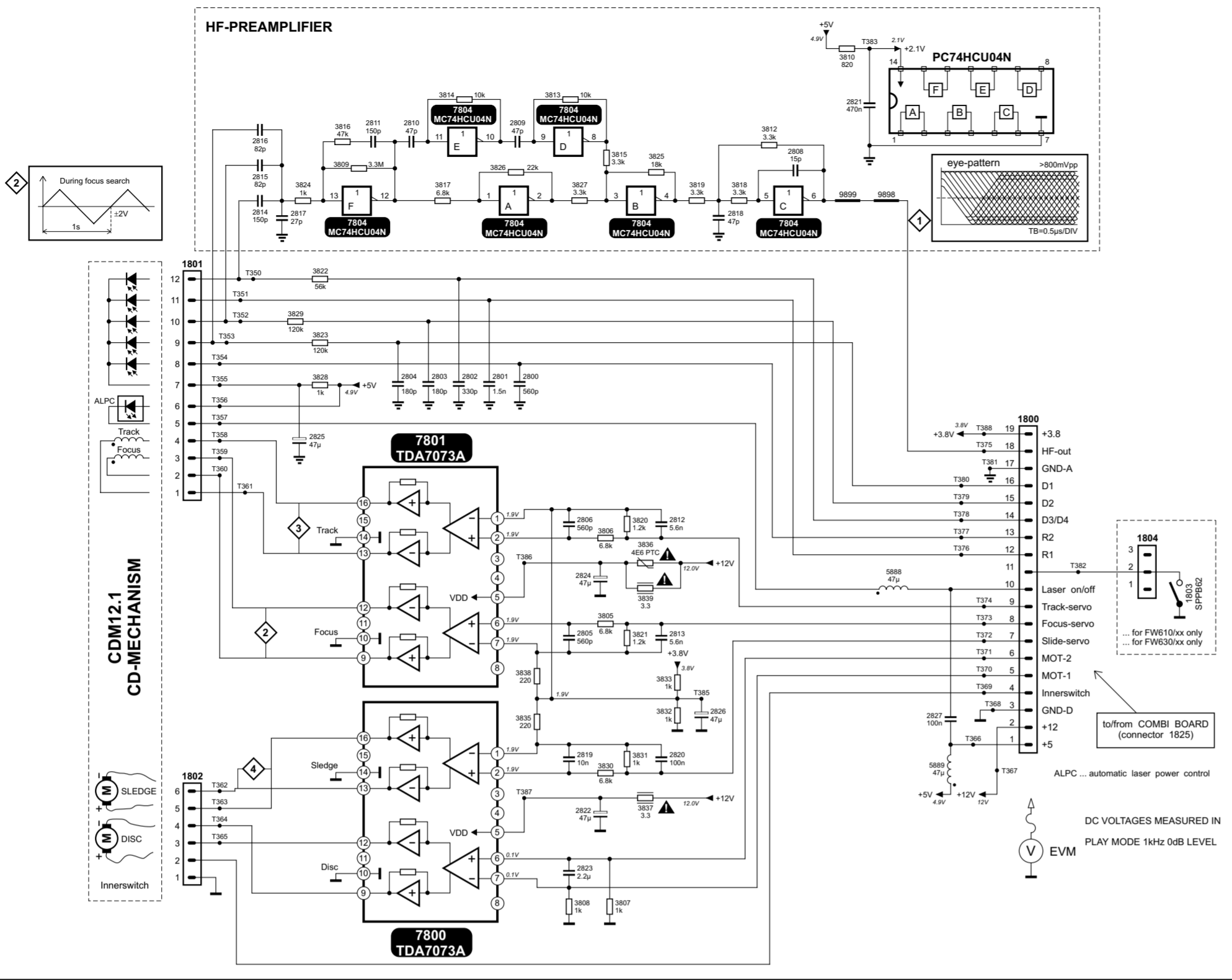

CD INTERFACE BOARD

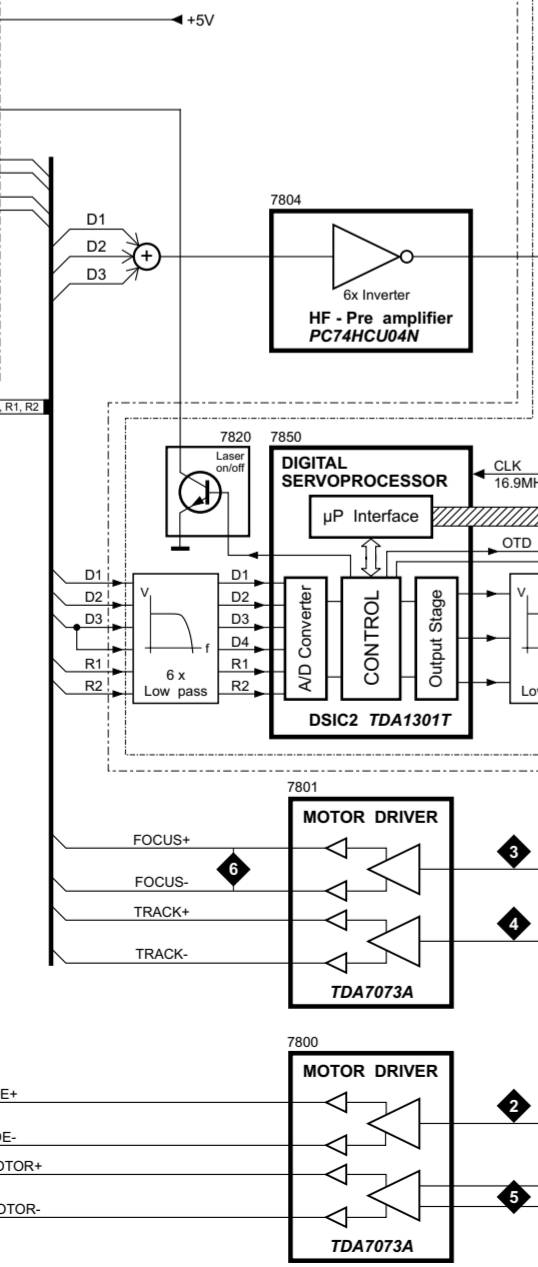

COMBI BOARD

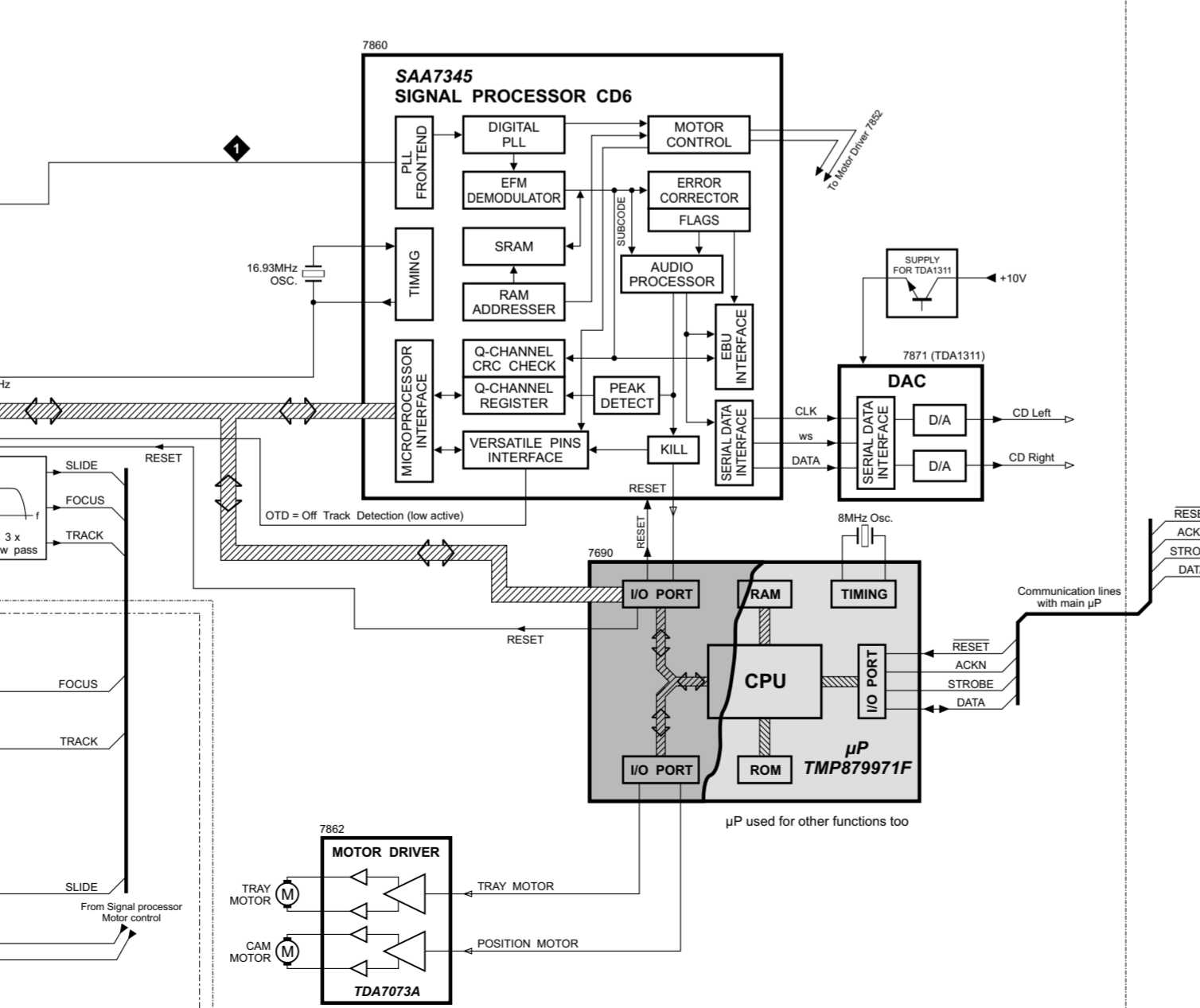

TUNER MINI 94

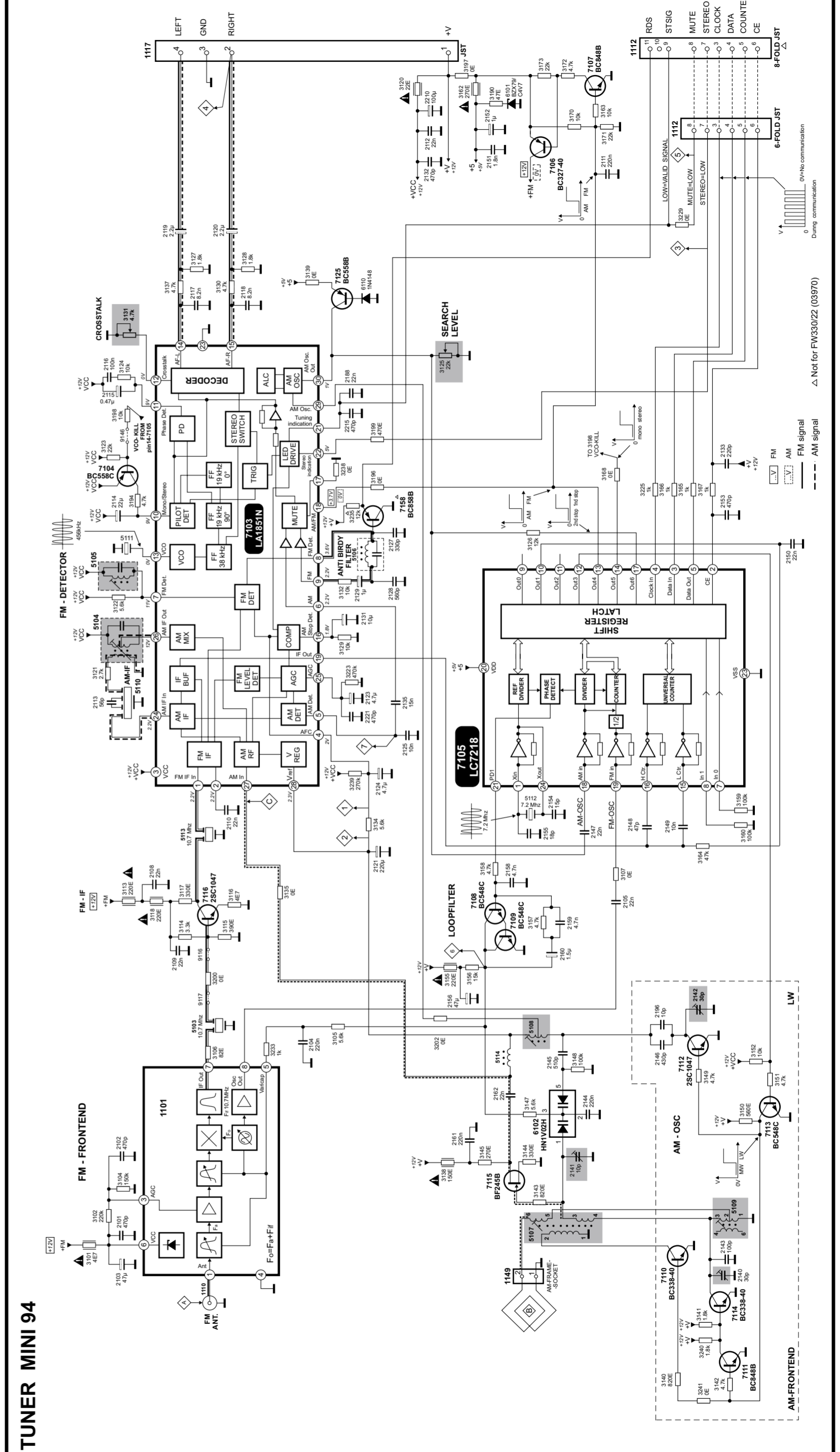

TUNER BOARD ECO5 / Systems

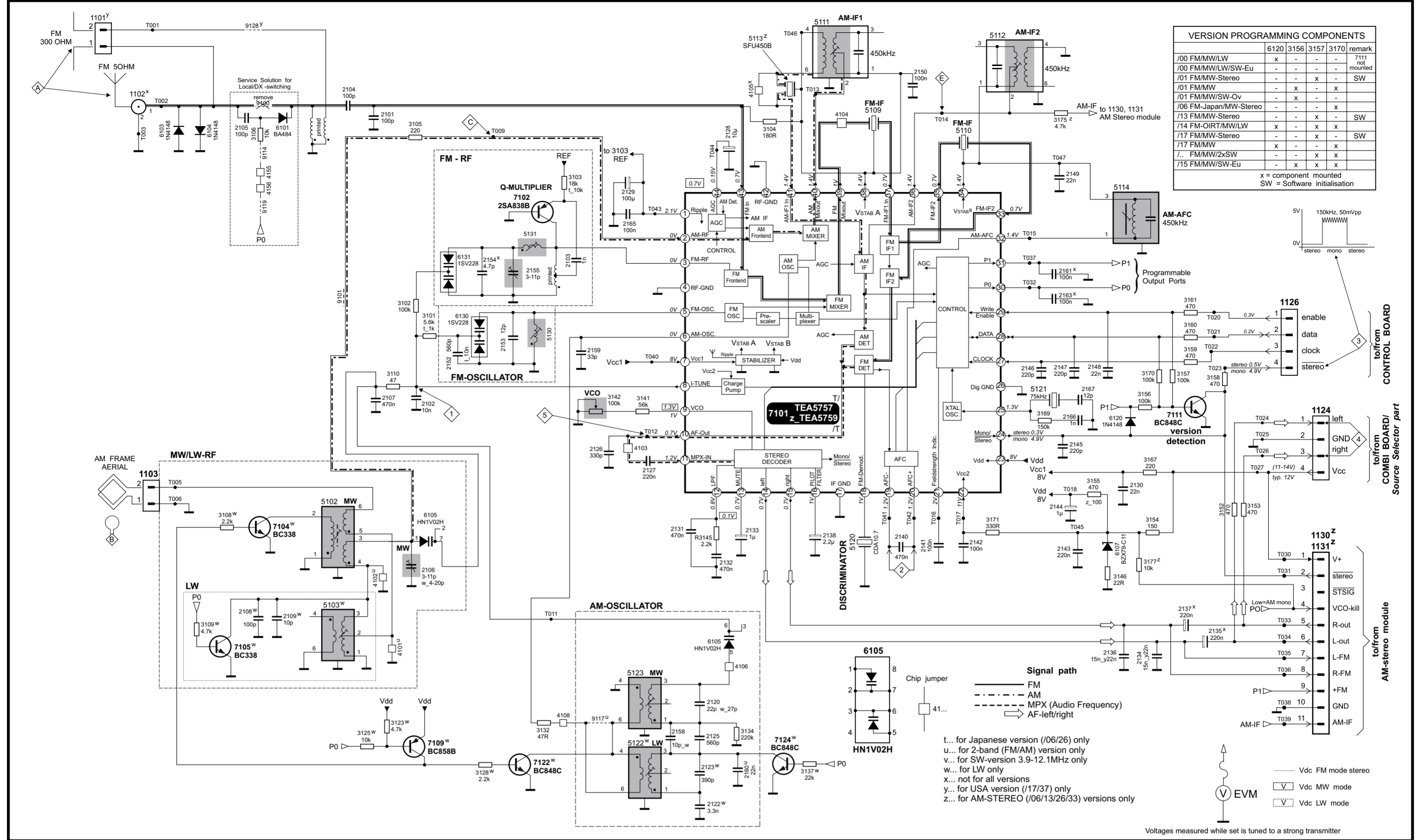

COMBI AF-PART

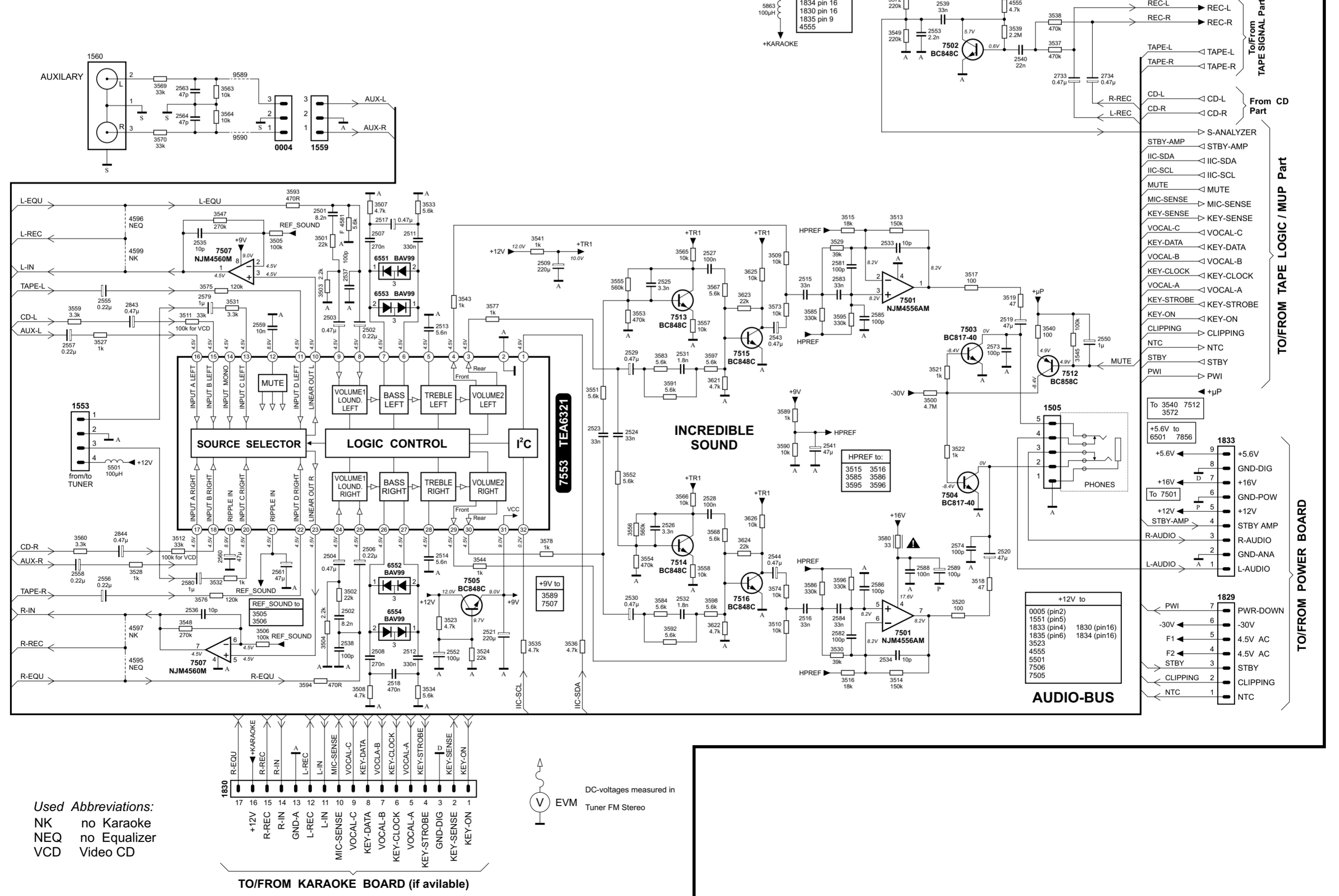

COMBI TAPE SIGNAL PART

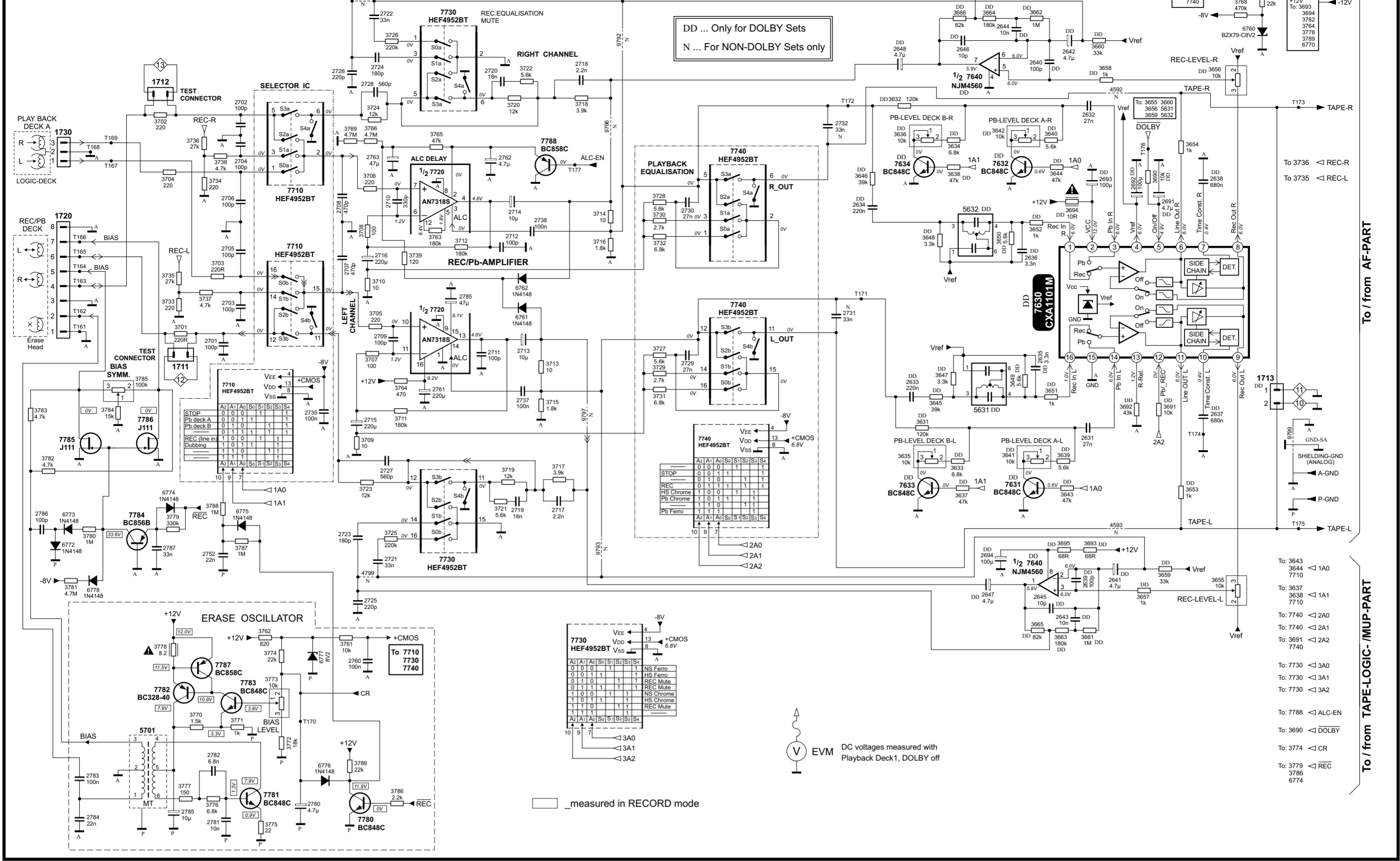

To / from AF-PART
To / from TAPE-LOGIC-/MUP-PART

COMBI TAPE SIGNAL PART

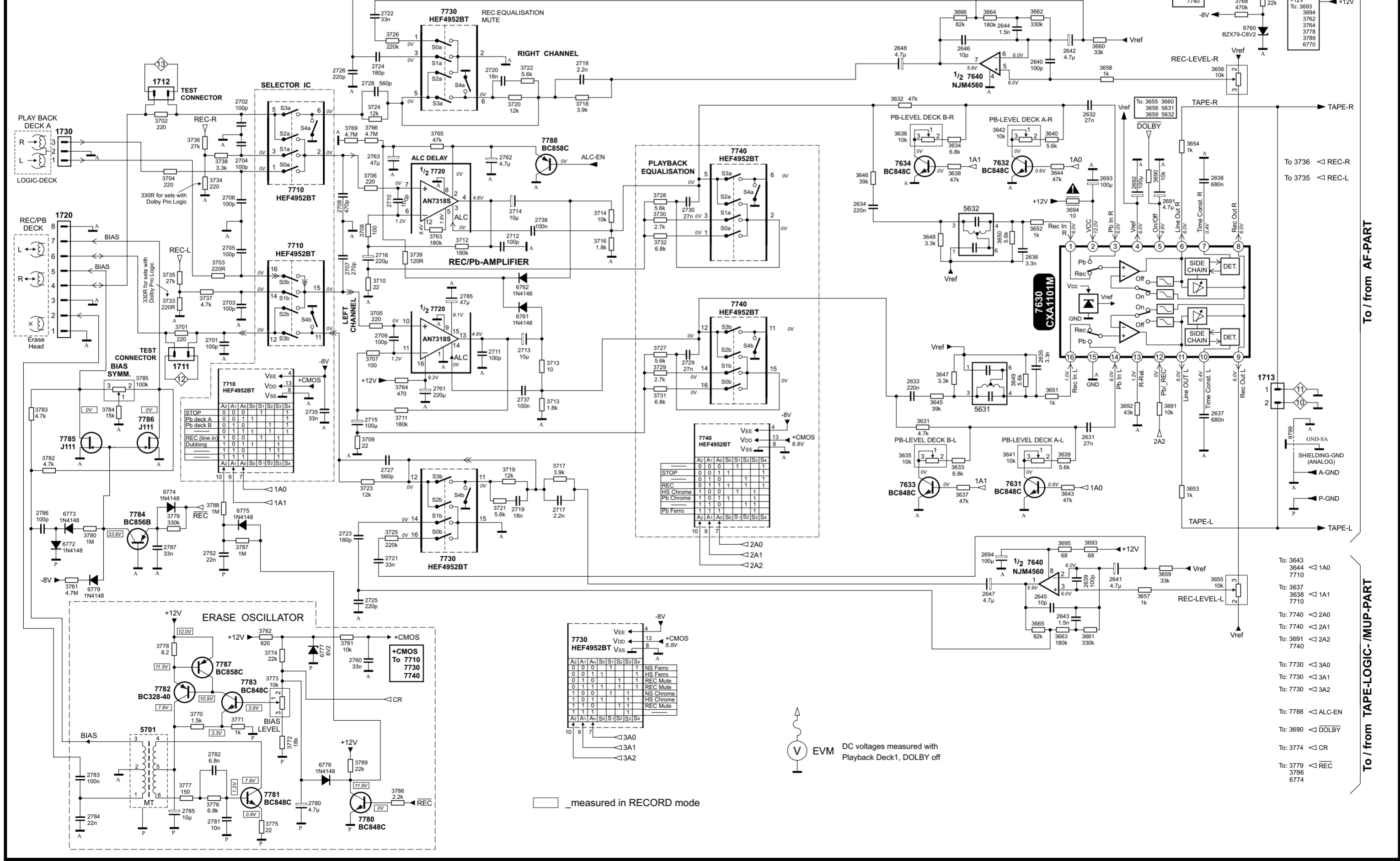

To / from AF-PART
To / from TAPE-LOGIC-/MUP-PART

COMBI CD-PART

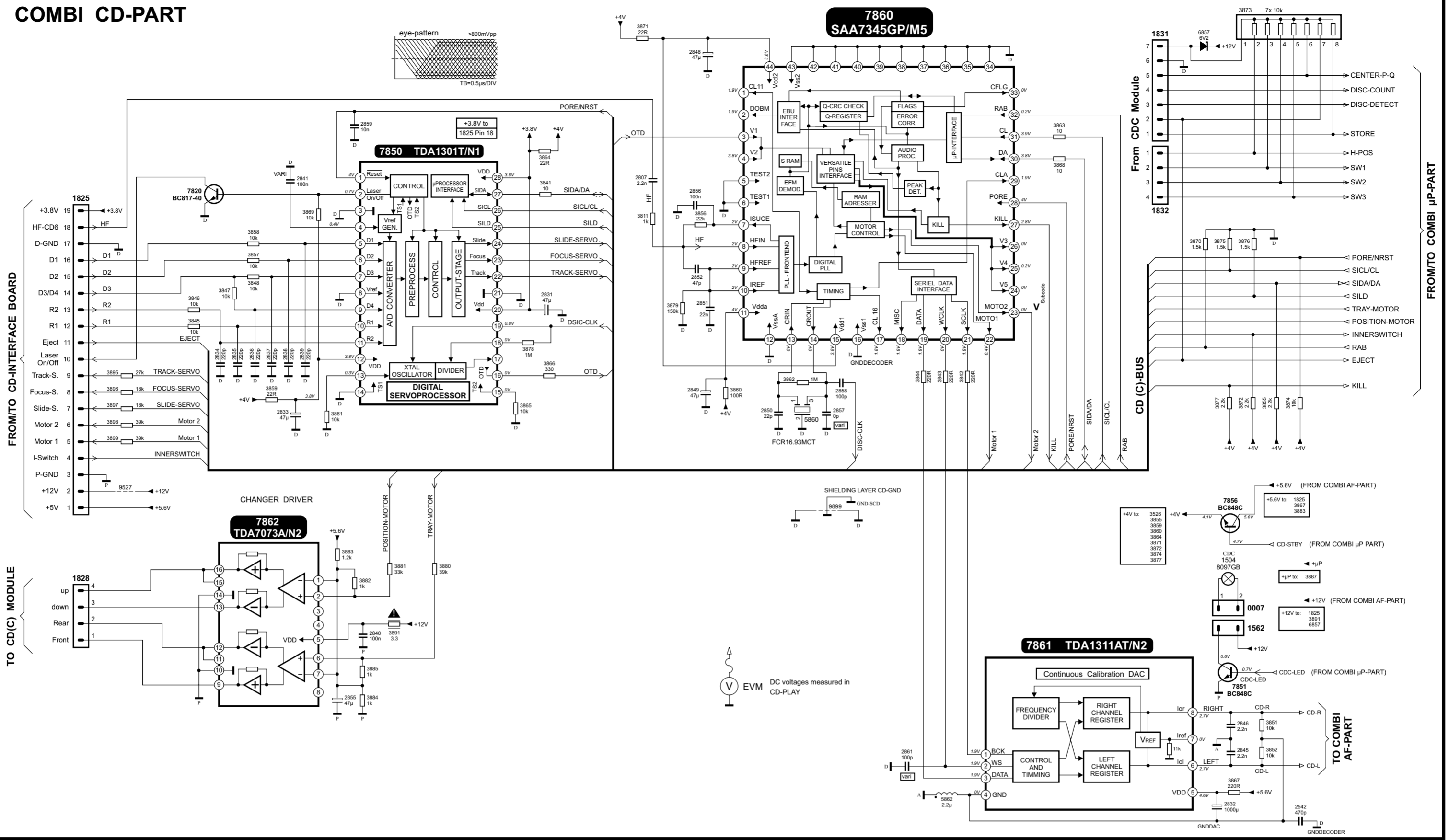

COMBI CD-PART

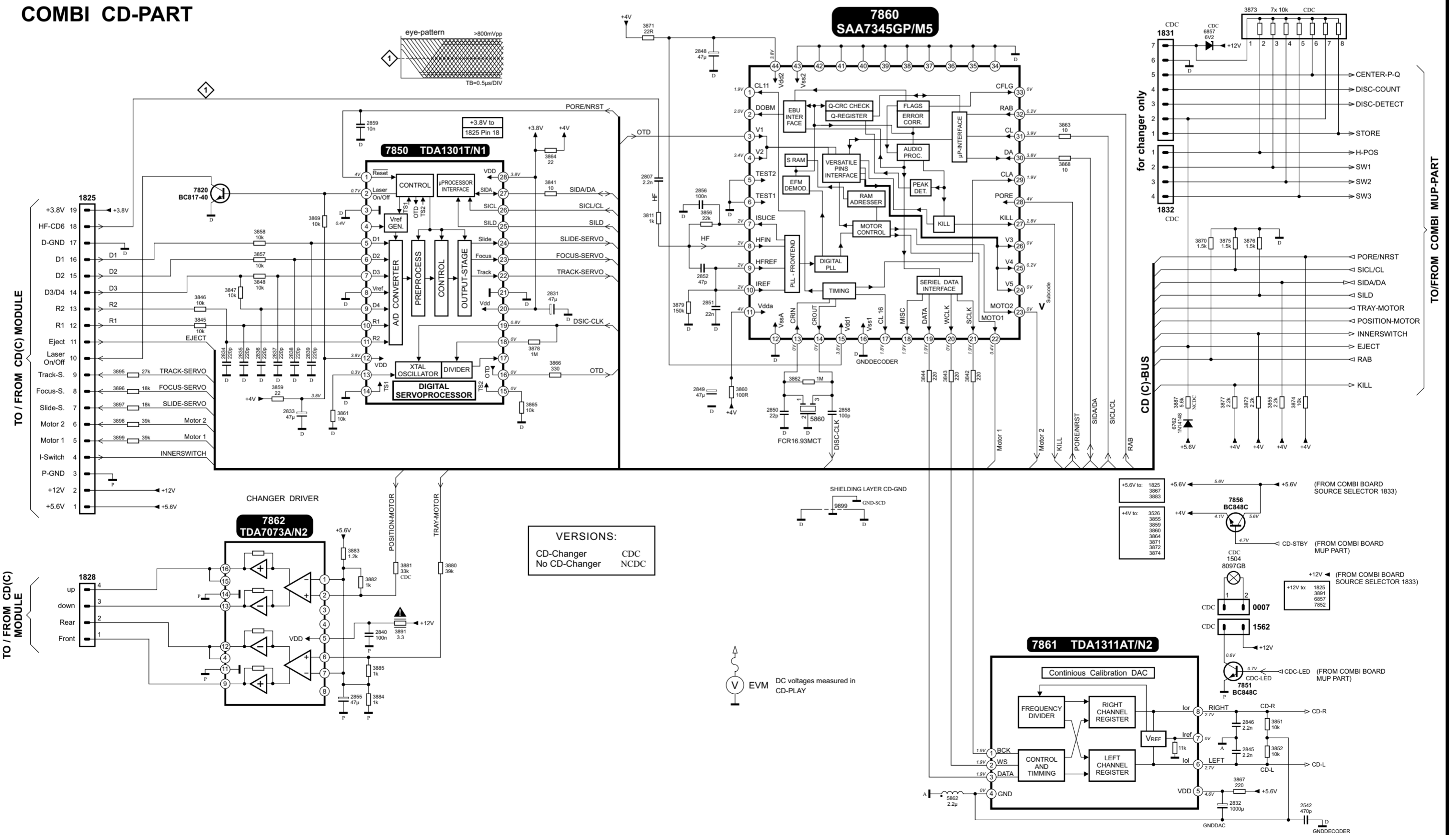

TUNER 95

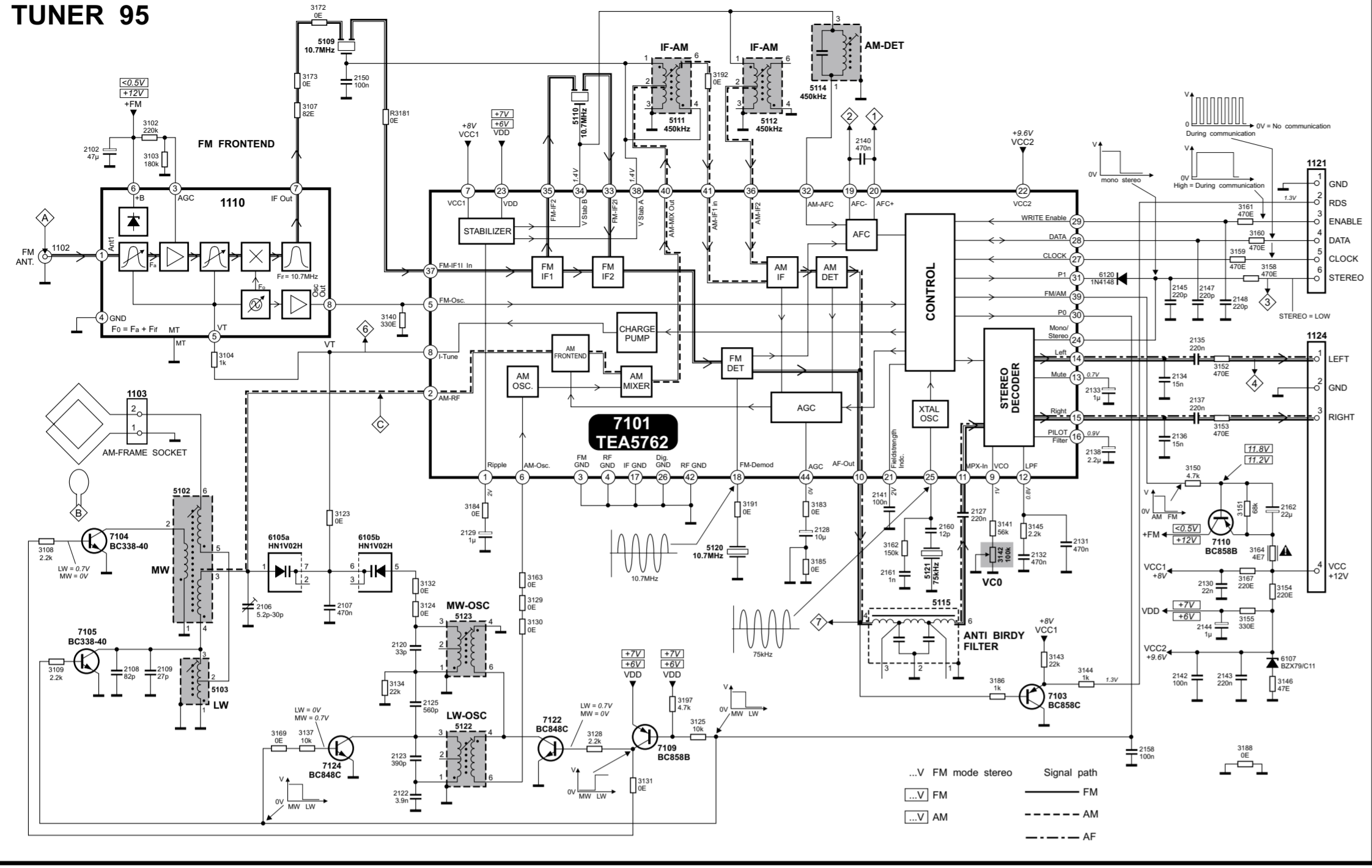

KARAOKE BOARD

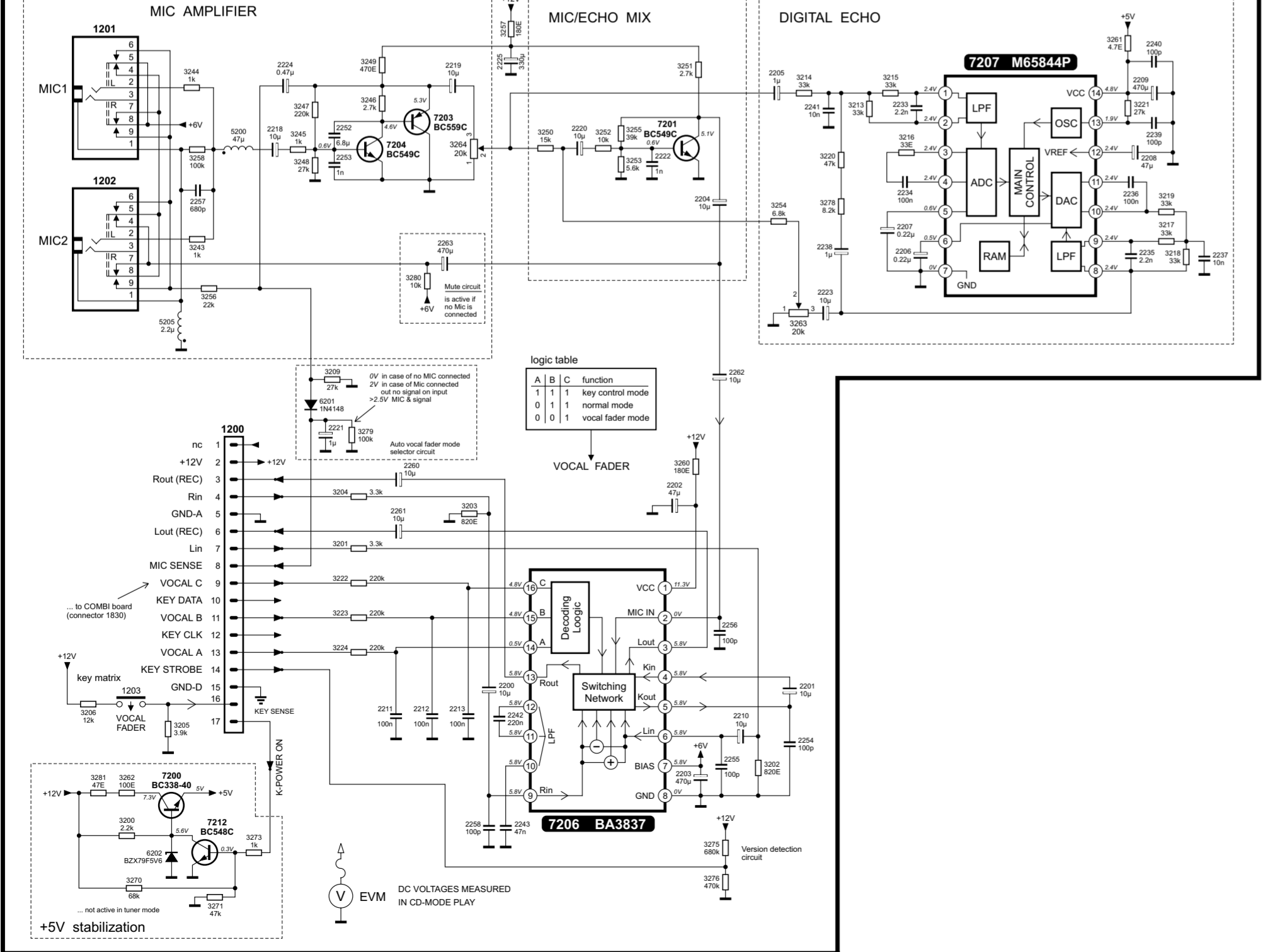

COMBI TAPE LOGIC / MUP PART

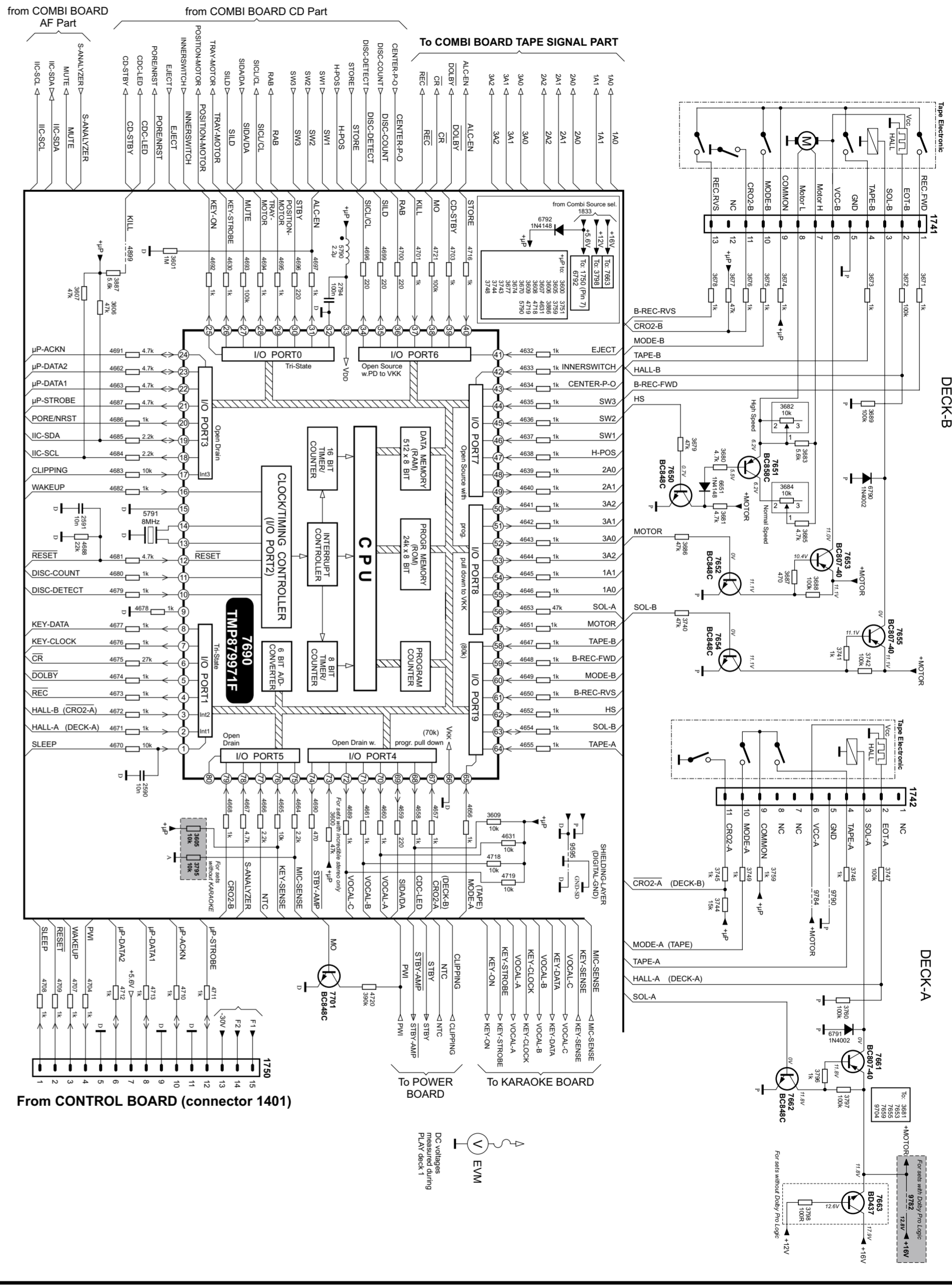

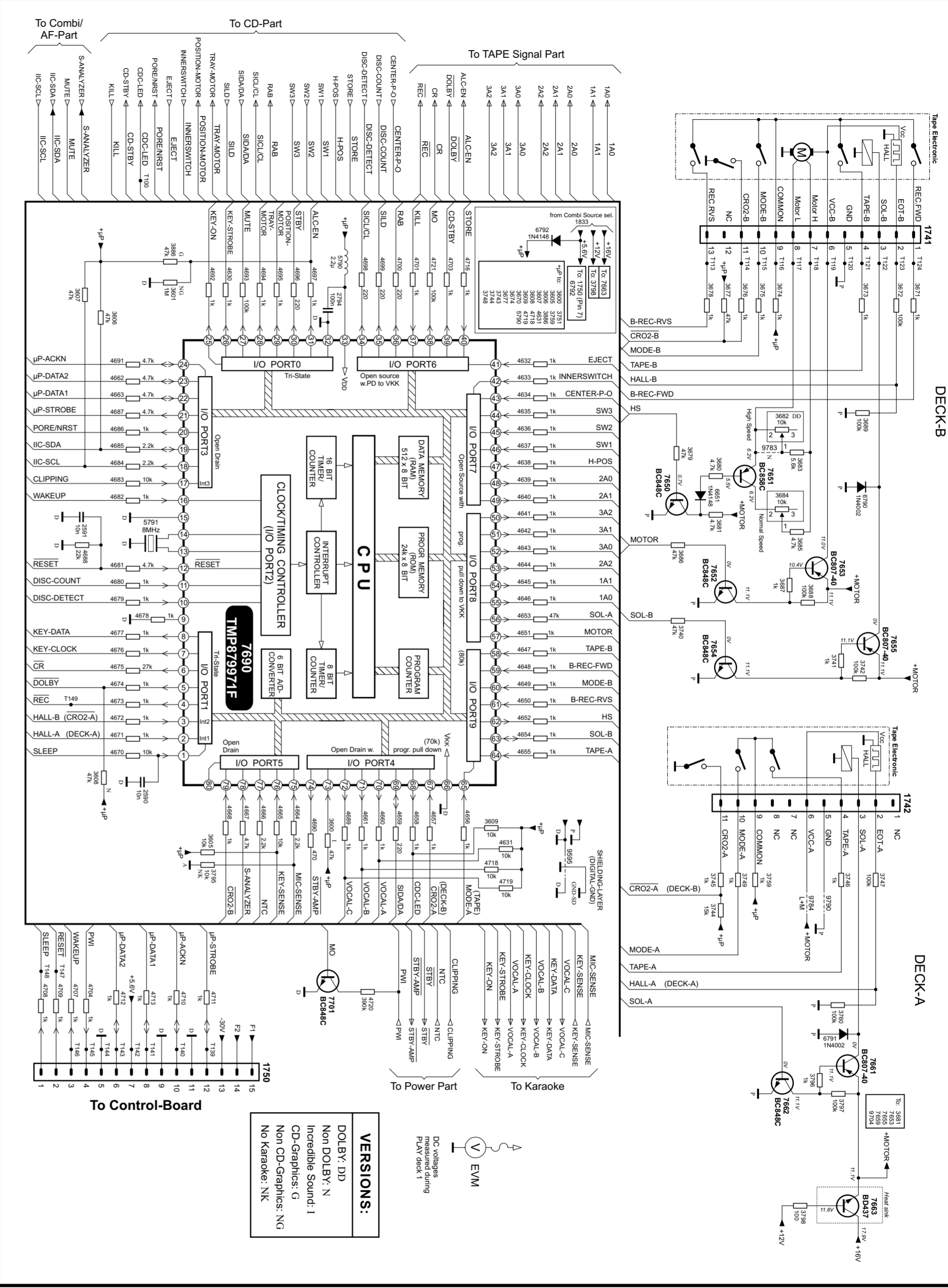

POWER BOARD AF PART

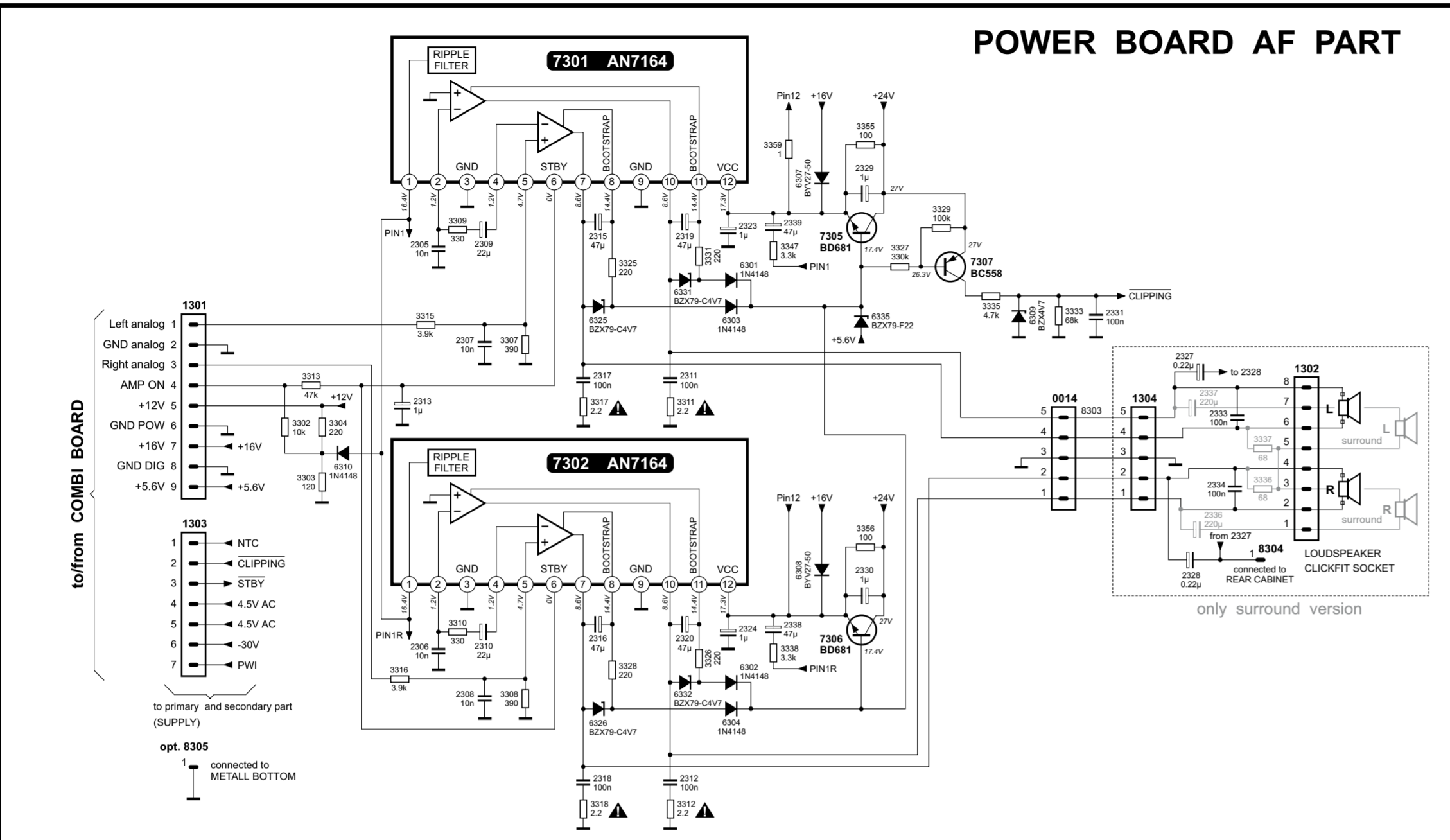

POWER BOARD SUPPLY PART

